

**Collection Moll**  
**12763010000 Spare paper holder**

**PRODUCT**

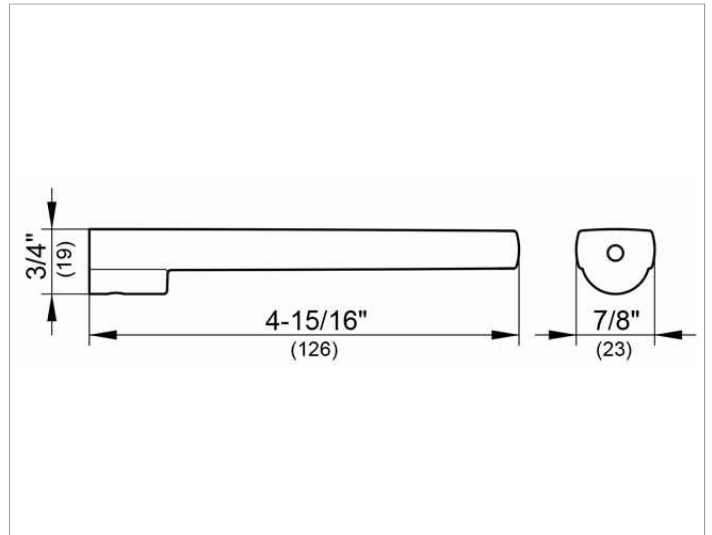

**DRAWING**



**SURFACE**

chrome-plated

**SPECIFICATIONS**

KEUCO COLLECTION MOLL spare paper holder 12763010000  
 Chrome-plated spare paper holder in an esthetic design, holder with slightly rounded edges, easy to clean, wall mounted  
 Projection: 4-15/16"  
 The spare paper holder is fitted with 1 hidden fixing point incl. corrosion-free mounting material

**Warranty:** KEUCO products are covered by a 5-year manufacturer's warranty, in effect from the date of purchase. During this time, proven product defects will be remedied free of charge. Warranty claims must be filed in writing, including a detailed description of the defect immediately after a defect has occurred. For a copy of our detailed product warranty policy, please contact us at [office-usa@keuco.com](mailto:office-usa@keuco.com).  
**Installation:** KEUCO products must be installed by a qualified professional in accordance with the respective installation guidelines and any applicable federal / local building codes and regulations.