

**Collection Moll**

12759010001 Shower basket

**PRODUCT**



**DRAWING**

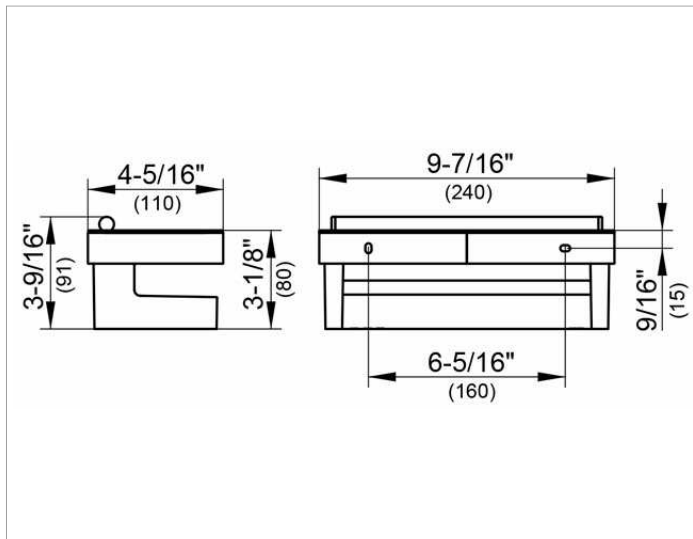

**PRODUCT ATTRIBUTES**

3 parts: metal bracket, detachable synthetic insert, soap resistant, shatterproof, UV-protected and integrated squeegee

**SURFACE**

chrome-plated/anthracite

**SPECIFICATIONS**

KEUCO COLLECTION MOLL shower basket, with integrated glass scraper, wall mounted 12759010001  
 Glass scraper, aluminum silver anodized, width 8-11/16", height 2-3/8"  
 Chrome-plated metal basket with removable, soap resistant, break-proof and UV- protected, anthracite, easy to clean  
 Total depth 4-5/16", height 3-1/8", total width 9-7/16"  
 The shower basket is fitted with 2 hidden fixing points incl. corrosion-free mounting material

**Warranty:** KEUCO products are covered by a 5-year manufacturer's warranty, in effect from the date of purchase. During this time, proven product defects will be remedied free of charge. Warranty claims must be filed in writing, including a detailed description of the defect immediately after a defect has occurred. For a copy of our detailed product warranty policy, please contact us at [office-usa@keuco.com](mailto:office-usa@keuco.com).  
**Installation:** KEUCO products must be installed by a qualified professional in accordance with the respective installation guidelines and any applicable federal / local building codes and regulations.